

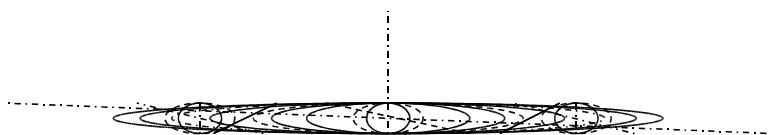

**CAPESTANO LAND ROVER**  
**part. 1 ( flangia calettata su albero motore )**



**CAPESTANO LAND ROVER**  
**part. 2 ( flangia di accoppiamento a omonima calettata su albero motore )**

Pag. 80%-pixel 3=col. 0,25;rig. 2,25	mm 6,40	=	Colonne n°	9,44	trasf. A	sessagesimale			sessadecimale		
Scala disegno 1 : 1,0 u.m. mm	mm 1,00	=	Righe n°	1,69		°	'	''			
						45	30	30	45.508333333333		

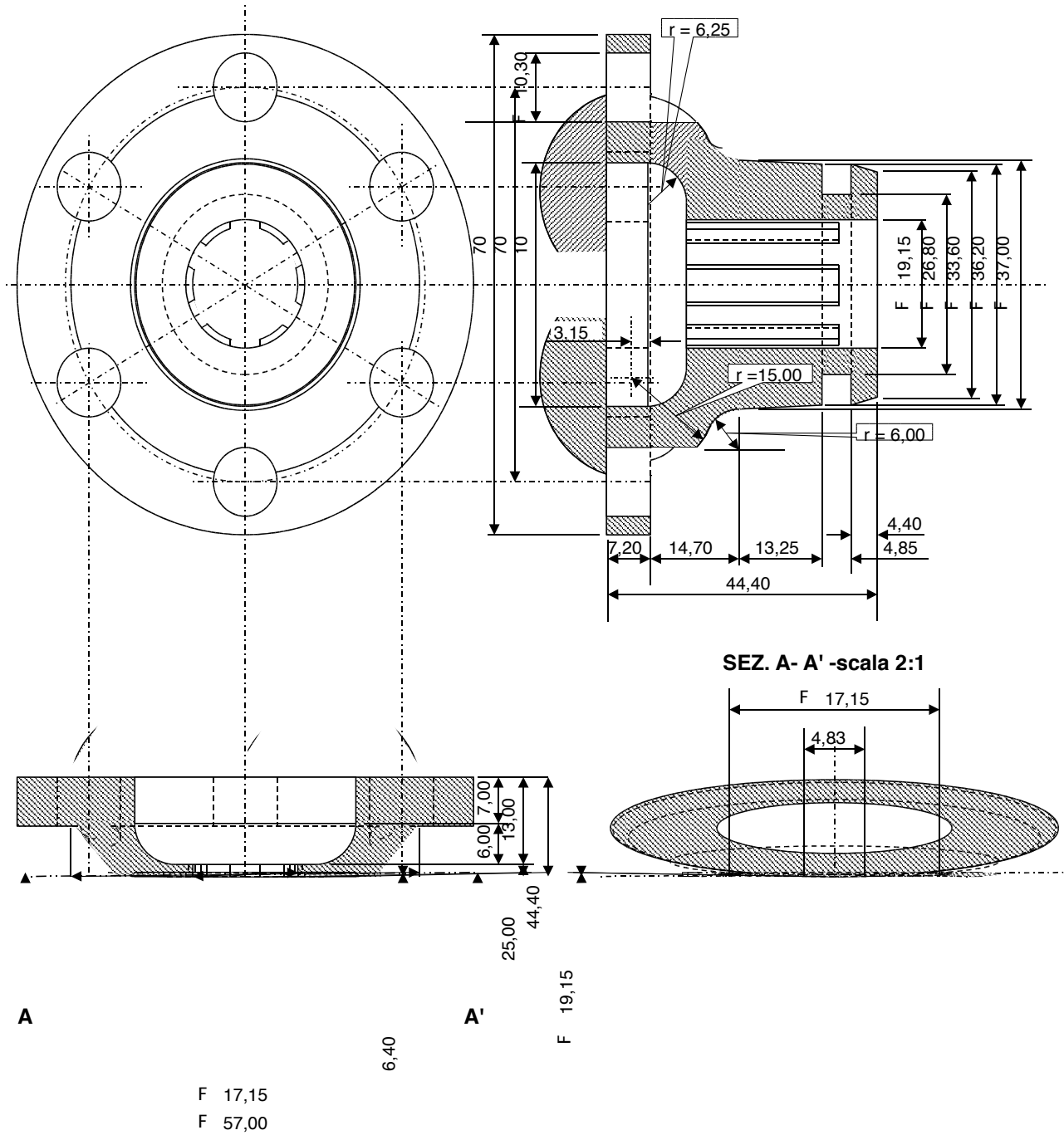

**CAPESTANO LAND ROVER**  
**part. 3 ( albero di accoppiamento a flangia part. 2 )**

Pag. 80%-pixel 3=col. 0,25;rig. 2,25	mm	3,50	=	Colonne n°	5,16	trasf. A	sessagesimale	sessadecimale
Scala disegno	1	:	1,0	u.m.	mm	mm	45	30
							30	45,508333333333

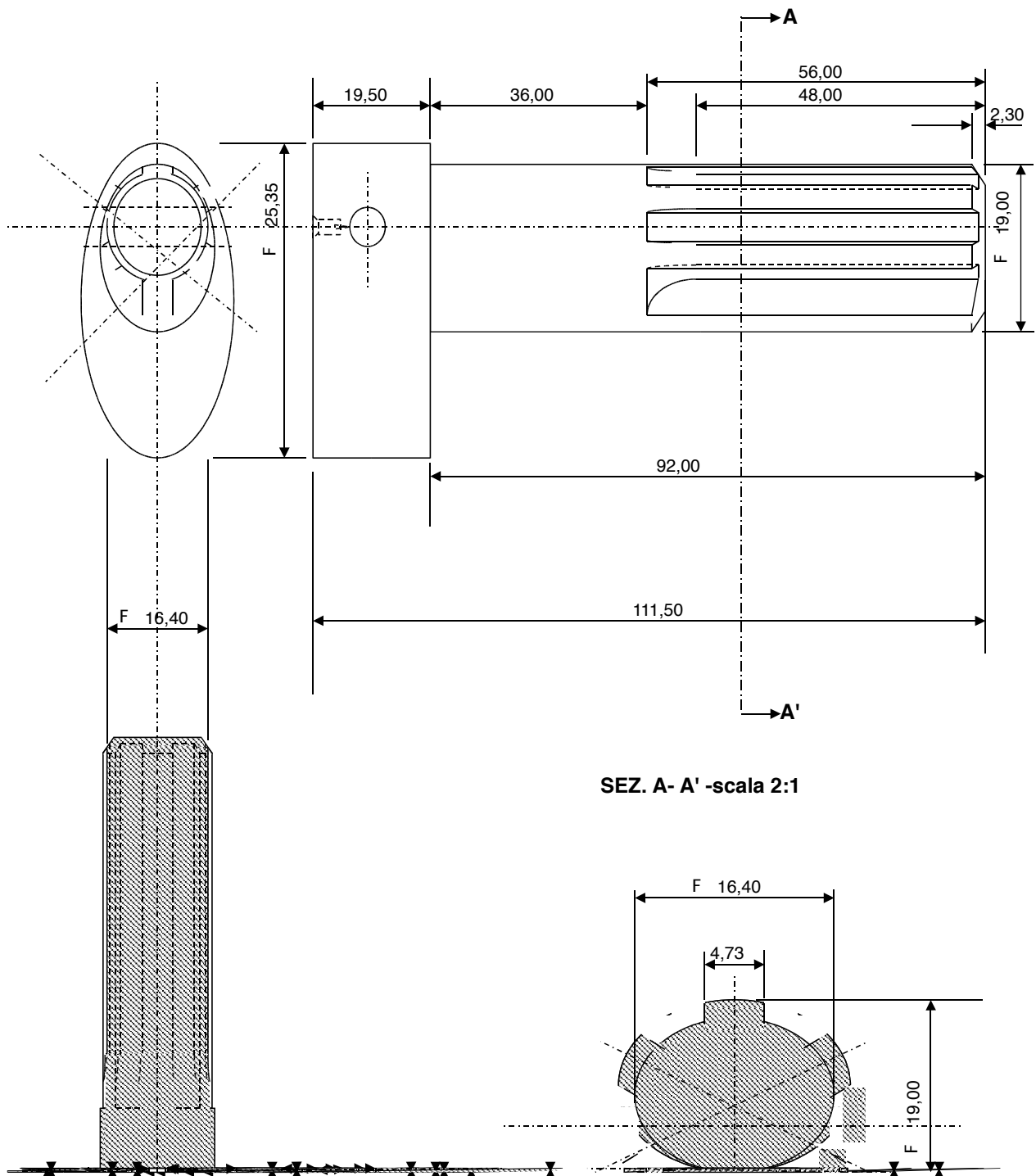

**SEZ. A- A' -scala 2:1**

**CAPESTANO LAND ROVER**  
**part. 3 ( albero di accoppiamento a flangia part. 2 )**

F 6,00

F 2,50

F 3,50

10,50

4,50

**CAPESTANO LAND ROVER**  
**part. 3 ( albero di accoppiamento a flangia part. 2 )**

mm	<b>24,20</b>	=	Colonne n°	<b>35,69</b>
mm	<b>24,20</b>	=	Righe n°	<b>40,90</b>

**INSIEME**

F 24,20

F 19,15

F 34,90

**CAPESTANO LAND ROVER**  
**part. 3 (albero di accoppiamento a flangia part. 2)**

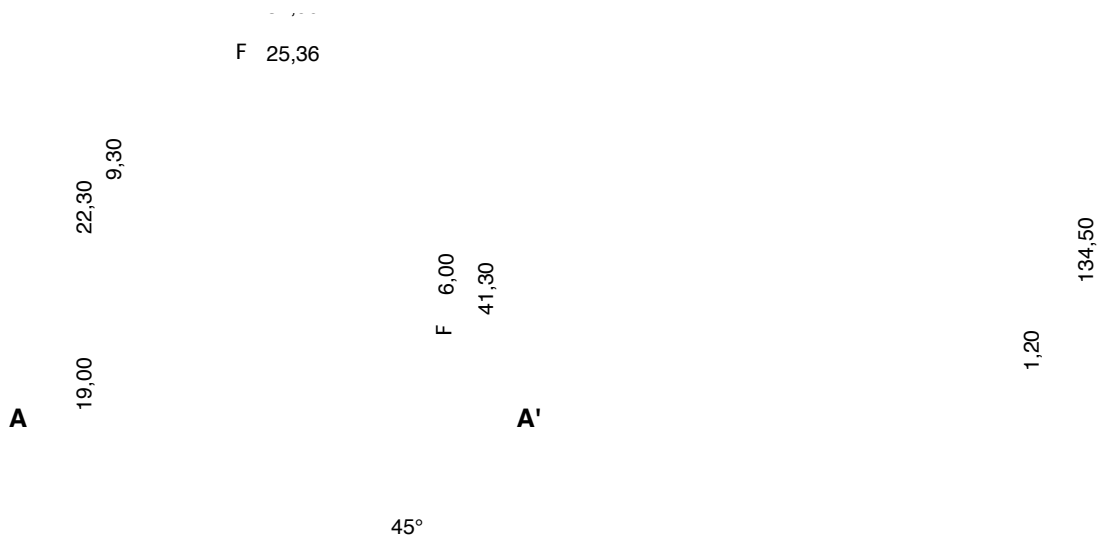

**SEZ. A- A' -scala 2:1**

F 19,15

3,68

**CAPESTANO LAND ROVER**  
**part. 3 ( albero di accoppiamento a flangia part. 2 )**

F 24,20



**CAPESTANO LAND ROVER**  
**part. 4 ( alberino di collegamento a capestano )**

Pag. 80%-pixel 3=col. 0,25;rig. 2,25	mm	24,50	=	Colonne n°	36,13	trasf. A	sessagesimale			sessadecimale					
Scala disegno	1	:	1,0	u.m.	mm	mm	4,40	=	Righe n°	7,44		45	30	30	45,508333333333

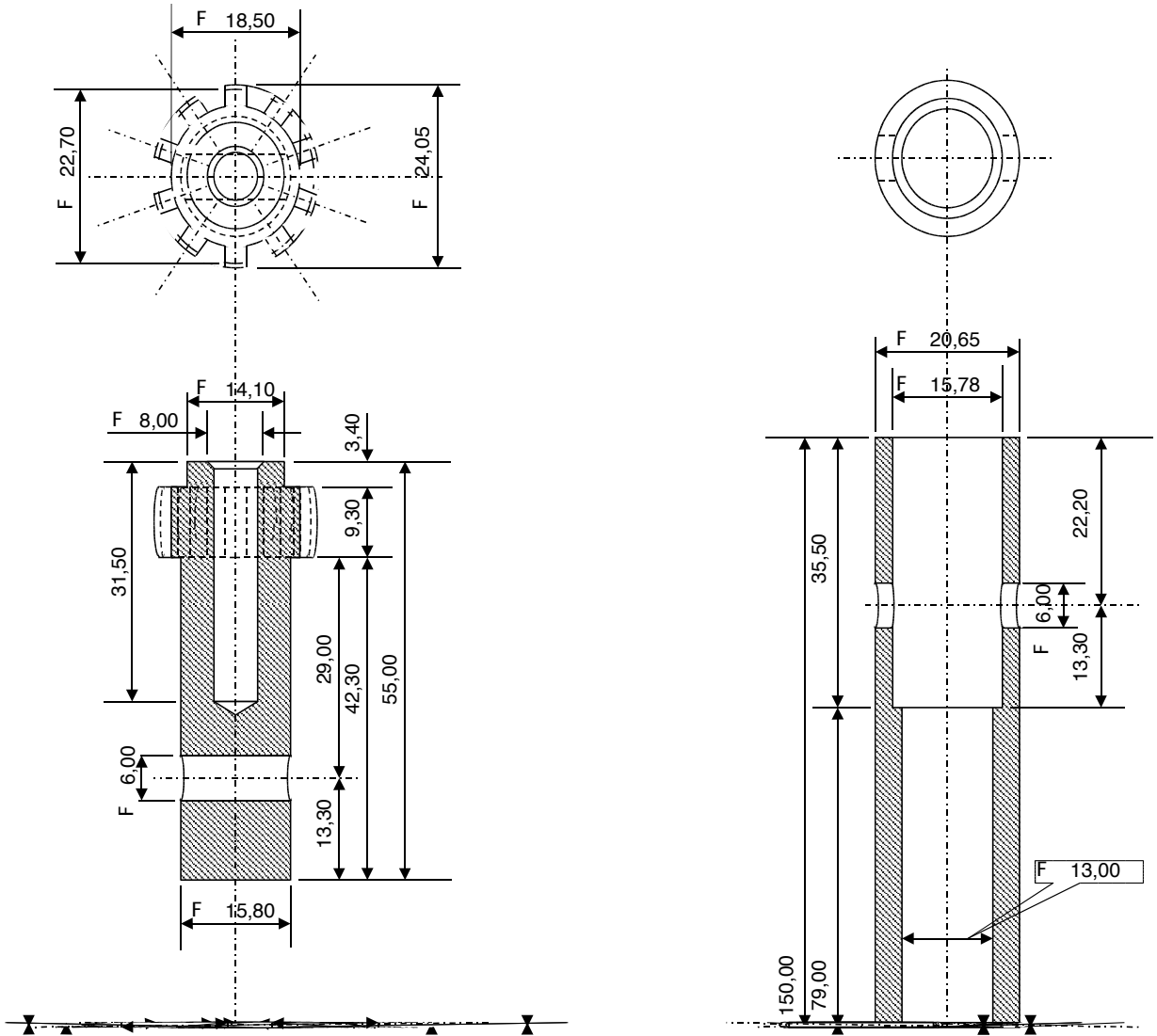

r = 12,05

35,50

**A** F 6,40

**A'**

**CAPESTANO LAND ROVER**  
**part. 4 ( alberino di collegamento a capestano )**

mm	<b>14,10</b>	=	Colonne n°	<b>20,79</b>
mm	<b>14,10</b>	=	Righe n°	<b>23,83</b>

**SEZ. A- A' -scala 2:1**

3,15

**INSIEME**

6,80

F 22,70

F 24,05

F 18,50

**CAPESTANO LAND ROVER**  
**part. 4 ( alberino di collegamento a capestano )**

189,00

**CAPESTANO LAND ROVER**  
**part. 4 ( alberino di collegamento a capestano )**

6,80

**CAPESTANO LAND ROVER**  
**insieme organo di trasmissione**

Pag. 80%-pixel 3=col. 0,25;rig. 2,25	mm	6,40	=	Colonne n°	9,44	trasf. A	sessagesimale			sessadecimale				
Scala disegno	1	:	1,0	u.m.	mm		mm	56,00	=	Righe n°	94,65	°	'	''
											45	30	30	45.508333333333

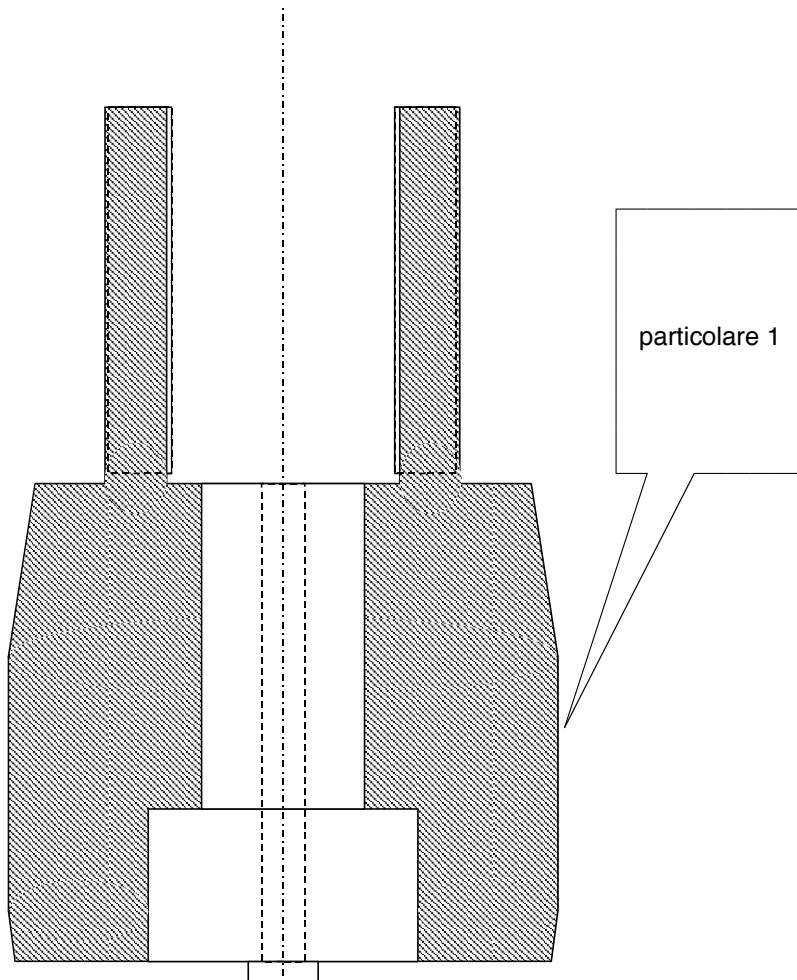

**CAPESTANO LAND ROVER**  
**insieme organo di trasmissione**

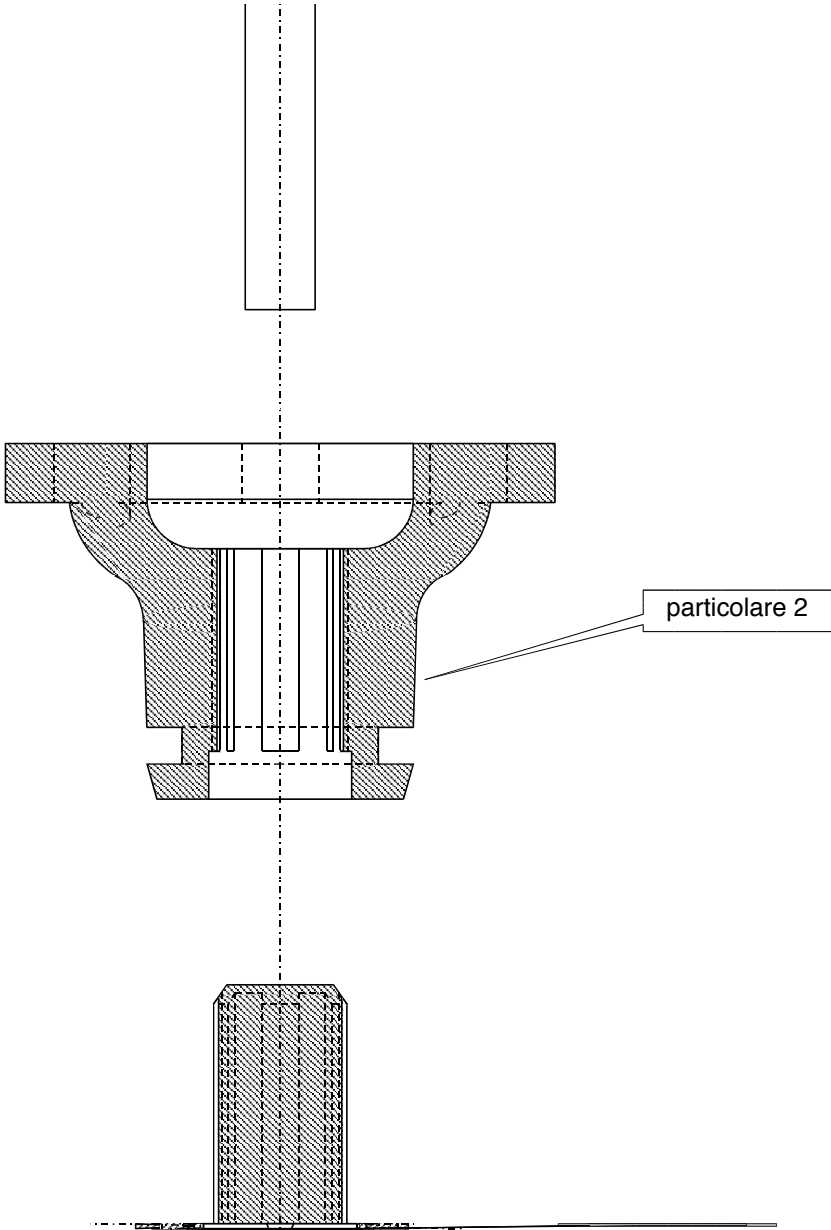

<b>Pag. 80%-pixel 3=col. 0,25;rig. 2,25</b>				mm	<b>6.40</b>	=	Colonne n°	<b>9,44</b>	trasf. A	<b>sessagesimale</b>			<b>sessadecimale</b>	
<b>Scala disegno</b>	<b>1</b>	<b>:</b>	<b>1.0</b>	<b>u.m.</b>	<b>mm</b>	mm	<b>56.00</b>	=		Righe n°	<b>94.65</b>	°	'	''
											45	30	30	45.508333333333